

Face Plate

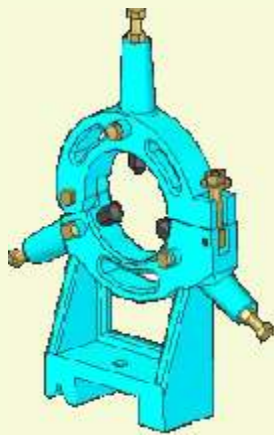

Steady Rest



Follow Rest

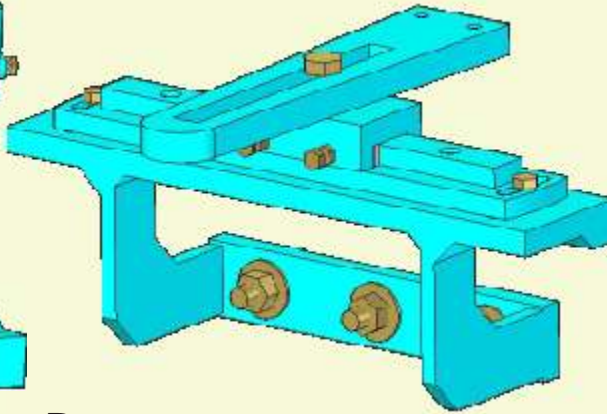

Taper Turning Att.

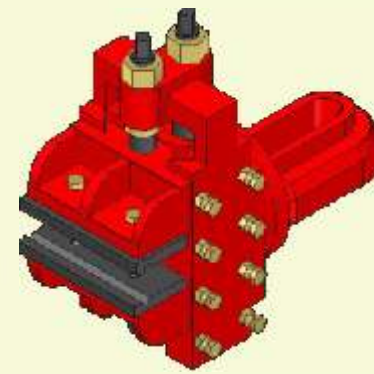

Key Way Vise

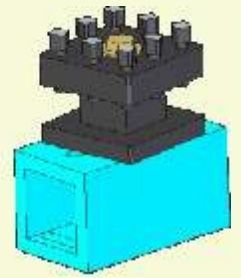

Rear Tool Post

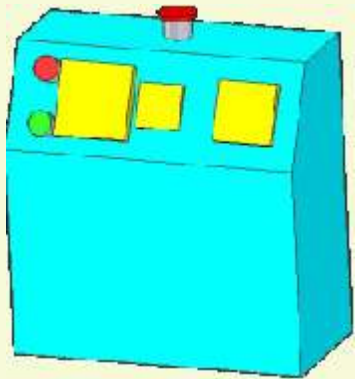

C.Panel Board



Chuck Guard

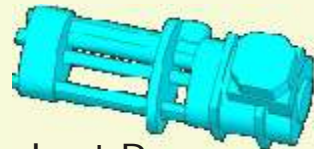

Coolant Pump



Coolant Stand



Coolant Pipe

Coolant Pump  
SP Type



Coolant Tank

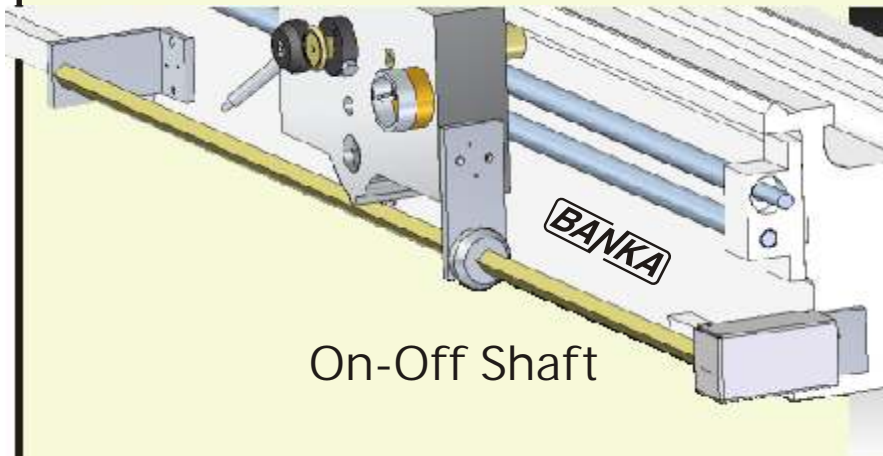

On-Off Shaft



Splash Guard



Machine Lamp



Revolving Center

# RAVI MACHINE PRODUCTS

2, Samrat Industrial Area, Gondal Road, Rajkot 360 004.  
Ph.: 0281-2372723, Mo.: 0 93741 02898  
Email: info@ravimachines.com Website: www.ravimachines.com



## Extra Accessories & Arrangement Price list

W.e.f. 1st July 2010

Accessories / Model	34-4.5'	34-5'	35-6'	35-7'	40-6'	43-6'	43-8'	50-7'	50-9'	60-9'	60-12'
Ele. Motor 2 HP ISI	5500	5500	5500	5500	5500			-	-	-	-
Ele. Motor 3 HP ISI	-	-	-	-	-	7340	7340	-	-	-	-
Ele. Motor 5 HP ISI	-	-	-	-	-	-	-	9100	9100	9100	9100
Ele. Motor 2 HP Non ISI	4750	4750	4750	4750	4750	-	-	-	-	-	-
Ele. Motor 3 HP Non ISI	-	-	-	-	-	6750	6750	-	-	-	-
Ele. Motor 5 HP Non ISI	-	-	-	-	-	-	-	8625	8625	8625	8625
R / F Switch with Wring	425	425	425	425	425	425	425	425	425	425	425
Control Panel Board	7250	7250	7250	7250	7250	7250	7250	7250	7250	7250	7250
Magnetic Brake, Panel Motor	18375	18375	18375	18375	18375	20215	20215	21975	21975	21975	21975
True Chuck 6" Swastik	4000	4000	-	-	-	-	-	-	-	-	-
True Chuck 8" Swastik	-	-	5125	5125	5125	5125	5125	-	-	-	-
True Chuck 10" Swastik	-	-	-	-	-	-	-	7175	7175	7175	7175
True Chuck 6" Sharp	5325	5325	-	-	-	-	-	-	-	-	-
True Chuck 8" Sharp	-	-	6675	6675	6675	6675	6675	-	-	-	-
Dog Chuck 8" Sharp	4500	4500	4500	4500				-	-	-	-
Dog Chuck 10" Sharp	-	-	-	-	5500	5500	5500	5500	5500	5500	5500
Chuck Plate 6-8"	1000	1000	1000	1000	-	-	-	-	-	-	-
Chuck / Driving Plate	1575	1575	1575	1575	1575	1575	1575	1575	1575	1575	1575
Face Plate	1875	1875	1875	1875	2250	2250	2250	2250	2250	3125	3125
Steady Rest	1875	1875	1875	1875	2125	2125	2125	3125	3125	3125	3125
Follow Rest	1225	1225	1225	1225	1575	1575	1575	1575	1575	2250	2250
Coolant Fittings SP Type	4875	4875	4875	4875	4875	-	-	-	-	-	-
Coolant Fittings Conventional	6250	6250	6250	6250	6250	6250	6250	6250	6250	6250	6250
Machine Lamp	600	600	600	600	600	600	600	600	600	600	600
Taper Turning Att.	5625	5625	5625	5625	5625	5625	5625	6875	6875	6875	6875
Splash Guard	4375	4875	5300	6125	5300	6550	7375	-	-	-	-
Chuck Guard	1125	1125	1125	1125	1125	1575	1575	1575	1575	1575	1575
Key Way Vise	3625	3625	3625	3625	3625	3625	3625	3625	3625	3625	3625
Key Way Att. With Motor	8125	8125	8125	8125	8125	8125	8125	8125	8125	8125	8125
Quick Change Tool Post	6125	6125	6125	6125	6125	6125	6125	8625	8625	8625	8625
Quick Change Tool Holder	875	875	875	875	875	875	875	1125	1125	1125	1125
Rear Tool Post	1875	1875	1875	1875	2250	2250	2250	2250	2250	2250	2250
Revolving Center	1125	1125	1125	1125	1125	1575	1575	1575	1575	1575	1575
Square Tool Post	1000	1000	1000	1000	1000	1000	1000	1000	1000	1000	1000
Universal Gear Box	-	-	13600	13600	13600	13600	13600	19550	19550	19550	19550
Carriage Stopper 4 Way	1225	1225	1225	1225	1225	1225	1225	1500	1500	1500	1500
Copy Turning Att.	5625	5625	5625	5625	5625	5625	5625	6875	6875	6875	6875
Dog Carriers Straig & Bent	1000	1000	1000	1000	1000	1000	1000	1000	1000	1000	1000
Grinding Fittings 6"	8625	8625	8625	8625	8625	8625	8625	8625	8625	8625	8625
Grinding Fittings 8"	16875	16875	16875	16875	16875	16875	16875	16875	16875	16875	16875
Milling Attachment	5000	5000	5000	5000	5000	6250	6250	6250	6250	6250	6250

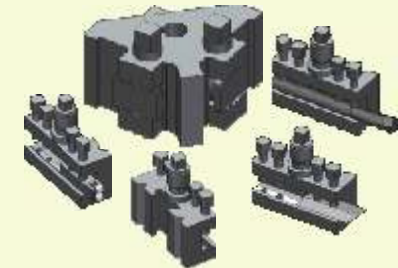

Quick Change Tool Post with Three Tool Holder



Dog Chuck

True Chuck



Electric Motor



Universal Gear Box



Semi Universal Gear Box



Key Way Att. With Motor

Note: We also provide customize Gap Piece in Bed, A1 & A2 Spindle Nose, Extra Center Height, Motor Two Speed, Digital Readout Z, Spindle Bore 50 & 80 mm, Special Colour, Speed and Thread as per your requirement. Charges applicable.

